

Chapter 7

Tessellations

GOAL

You will be able to

- use angle measurements to identify regular and irregular polygons that might tessellate
- identify and describe translations, reflections, or rotations in a tessellation
- use and describe ways to create a tessellation

- ◀ This tile pattern uses two different squares. Do you think a tiling pattern could be made using two or more types of triangles?

YOU WILL NEED

- Circle Wedges

Completing a Circle

Taira and Holly are determining the different angles that can be used to complete a circle. They are placing wedges at a point until the circle is completed.

? What angle should Taira and Holly use to complete the circle?

- How many angles of 60° can be used to complete the circle?
- How many angles of 90° can be used to complete the circle?
- List three other combinations of angles that make a complete circle.
- What angle should Taira and Holly use to complete their circle?

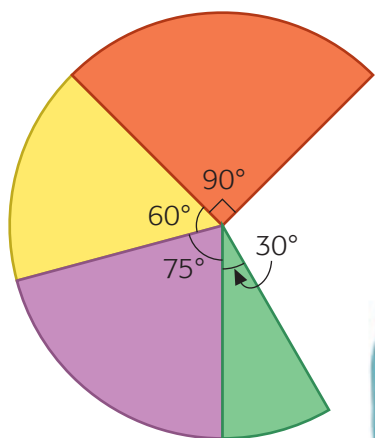

What Do You Think?

Decide whether you agree or disagree with each statement.
Be ready to explain your decision.

1. Every hexagon has six angles greater than 90° .



2. The only shape that makes a good floor tile is a rectangle.



3. If you cut a square floor tile into two shapes and rearrange the pieces, the new shape will also make a good tile.



7.1

Exploring Tiling

YOU WILL NEED

- Polygon Tiles
- Polygon Tiles Cards I
- Polygon Tiles Cards II

GOAL

Use polygons to tile.

EXPLORE the Math

Lam is helping his mother design a tiling pattern for an outdoor table. He wants to use regular polygons in his design.

? Which shapes can Lam use to tile the tabletop?



7.2

Tessellating with Regular Polygons

YOU WILL NEED

- Polygon Tiles
- Polygon Tiles Cards I
- Polygon Tiles Cards II
- grid paper
- tracing paper

tessellation

the tiling of a **plane** with one or more congruent shapes without any gaps or overlaps

plane

a flat surface that goes on forever in two different directions

GOAL

Use angle relationships to identify regular polygons that tessellate.

LEARN ABOUT the Math

Angèle is designing a **tessellation** for a scrapbook page.

- She traced around a square to start the tessellation.
- She marked one vertex of the square.
- She lined up the sides and corners of each square she traced.

Angèle wants to design other scrapbook pages with tessellations of equilateral triangles and regular pentagons.

? Which of her regular polygons can Angèle use to tessellate her scrapbook page?



- A.** How many squares surround the first vertex (X) in Angèle's tessellation?

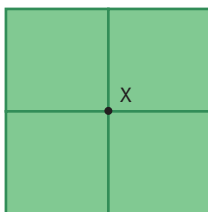

- B.** How many squares can surround vertex Y?

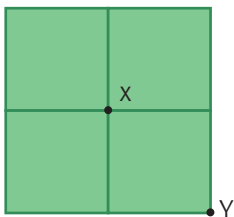

- C.** How do you know that Angèle's tessellation will cover the plane?

- D.** What is the measure of each interior angle in the square?



- E.** Determine the angle total at each vertex of your tessellation.
F. Record your data from parts A–D in the second column of a table like this one.

interior angle

the inside angles of a polygon

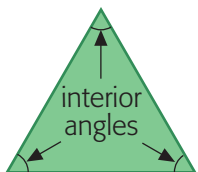

	Equilateral triangle	Square	Regular pentagon
Does the polygon tessellate? (yes or no)		yes	
Number of shapes at each vertex			
Interior angle measure			
Sum of angles at each vertex			

- G.** Predict the values for the table for equilateral triangles and regular pentagons. Test your prediction by trying to tessellate with those shapes.

Reflecting

- H.** How could you predict the number of angles that will fit together at the centre vertex from knowing the interior angle measure of each shape?
- I.** Could exactly three copies of any regular polygon fit around each vertex in a tessellation? Explain.

WORK WITH the Math

Example 1 | Predicting whether a shape will tessellate

Show whether a regular heptagon tessellates.

John's Solution



$$2 \times 129 = 258^\circ$$

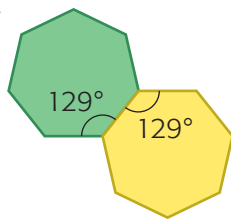

$$3 \times 129 = 387^\circ$$

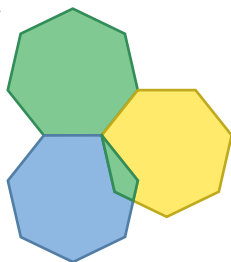

So regular heptagons do not tessellate.

I knew from measuring that the interior angles of a heptagon are about 129° each.

Two heptagons would cover about 258° . For the shape to tessellate, it has to cover 360° with no overlaps.

Three heptagons would cover about 387° . That is too much. The third heptagon would overlap the first two.

Communication *Tip*

When you say that a polygon will tessellate, it means that the polygon will tile a plane.

Reading Strategy

Predicting

Predict the answer to the question, complete the question, and check your solution with a partner.

A Checking

1. Try to tessellate with a regular hexagon. Explain why it does or does not work.

B Practising

2. Predict whether a regular octagon will tessellate. Explain.

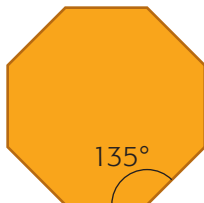

3. A regular dodecagon has interior angles of 150° .
 - a) Predict whether it will tessellate. Explain.
 - b) Predict whether a smaller, regular dodecagon will tessellate. Explain.

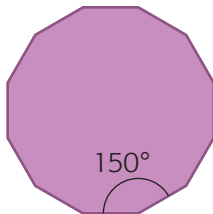

4. Jordan predicts that a regular decagon will tessellate. He says it will work because $360 \div 10$ is 36 with no remainder. Is Jordan right or wrong? Explain.

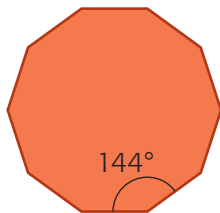

5. What has to be true about the size of the interior angle of a regular polygon for it to tessellate?

7.3

Tessellating with Quadrilaterals

YOU WILL NEED

- quadrilaterals
- grid paper
- tracing paper

GOAL

Create and describe tessellations of quadrilaterals.

LEARN ABOUT *the Math*

Renée is designing a stained glass window. She wants to tile it with only quadrilaterals.

? Which of Renée's quadrilaterals tessellate?



- A. Create a tessellation by translating or rotating a rectangle. Sketch your tessellation.
- B. Repeat part A with a parallelogram.
- C. Repeat part A with a rhombus.
- D. Which of the quadrilaterals can you use to tessellate?

Reflecting

- E. Compare your tessellations with those of a few classmates. Are they all the same?
- F. Look at the angles surrounding each vertex in the tessellations you sketched. What is the sum of the angles? How do you know?

WORK WITH the Math

Example 1

Using transformation to tessellate

Tessellate with this quadrilateral.



Holly's Solution



$$\angle 1 + \angle 2 + \angle 3 + \angle 4 = 360^\circ$$

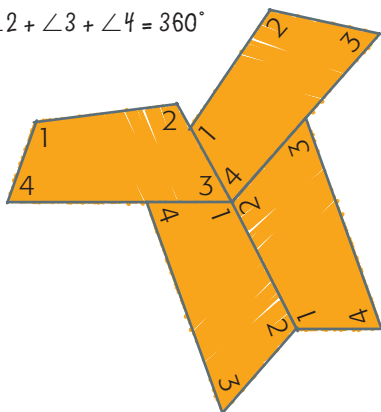

I knew that the interior angles of a quadrilateral always have a sum of 360° . I also knew that, for a shape to tessellate, the sum of the angles around the vertex has to be 360° .

I matched the quadrilaterals so that each angle, 1, 2, 3, and 4, appeared at each vertex once. The sum of the angles at the vertex was 360° , but I could not extend the pattern to make a tessellation.



midpoint

the point on a line segment that divides the line segment into two equal parts

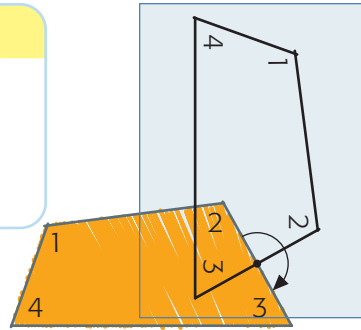

I traced the quadrilateral and rotated it about the **midpoint** of the side joining $\angle 2$ and $\angle 3$.

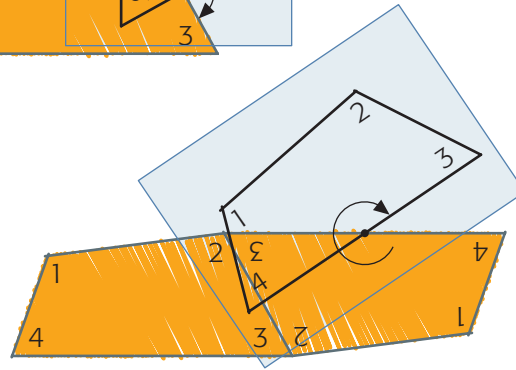

I rotated the quadrilateral about the midpoint of the side joining $\angle 3$ and $\angle 4$. Then I rotated the new quadrilateral again about the midpoint of the $\angle 1$ and $\angle 4$ side.

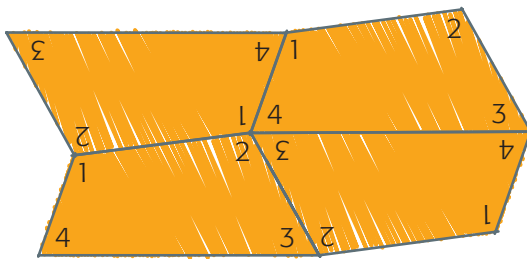

The sides matched, and the central vertex had an angle sum of 360° .

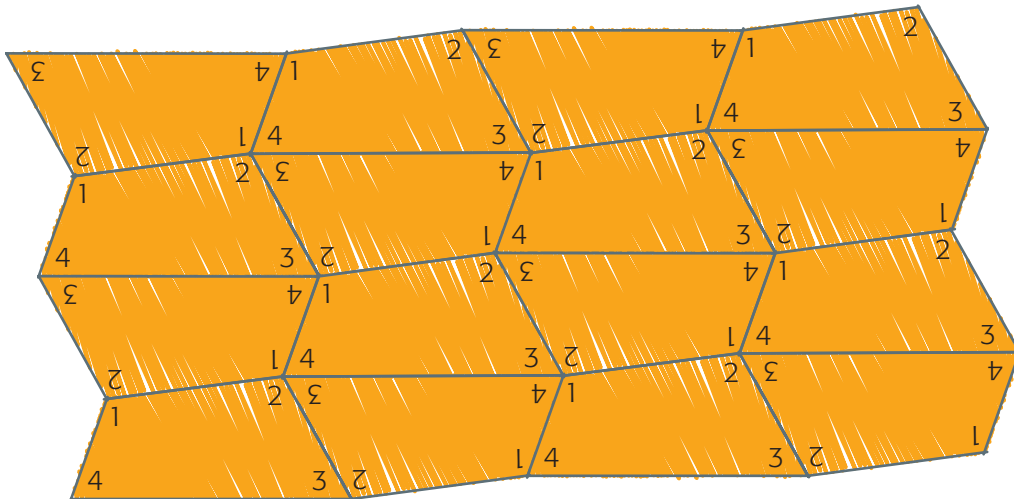

I continued until I knew the shapes could be repeated forever.
I know it is still a tessellation even though the edges are not straight.

A Checking

- a) Create your own quadrilateral.
b) Sketch a tessellation with your quadrilateral.
c) Describe how you tessellated with it.

B Practising

- a) Create a tessellation with rhombuses using only reflection and translation. Sketch your tessellation and describe it.
b) Repeat part a) using rotation about the midpoints of the sides.
- Sketch and describe two different tessellations with this right trapezoid.
- a) Create a kite.
b) Tessellate with the kite.
c) Sketch and describe the tessellation.
- a) Create a trapezoid.
b) Try to tessellate with it by rotating around a vertex.
c) Try to tessellate with it by reflecting and translating.
- Asuka wants to re-create this tessellation design. What transformation should she start with?

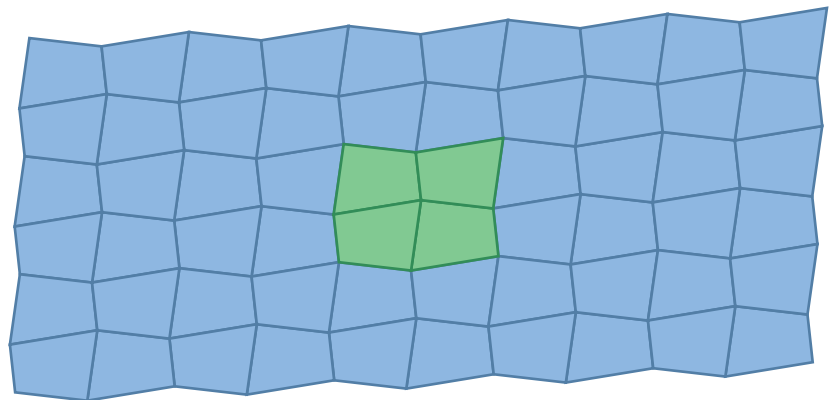
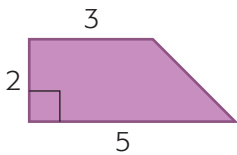

- a) Create a new quadrilateral you think may not tessellate.
b) Try to tessellate with your quadrilateral.
c) Did anybody in your class make a quadrilateral that did not tessellate? What do you think this means about quadrilaterals?

7.4

Tessellating with Triangles

YOU WILL NEED

- triangle tiles
- grid paper
- tracing paper

GOAL

Create and describe tessellations of triangles.

LEARN ABOUT *the Math*

Ivan notices that some tiles in his home are right isosceles triangles.

He wonders if other types of triangles tessellate.



? Which types of triangles tessellate?

- Divide a rectangle along its diagonal to create two right triangles. From what you know about rectangles, predict whether these triangles will tessellate. Explain your prediction.
- Try to tessellate with an acute isosceles triangle, using reflection and translation. Does it tessellate? Explain.
- Divide a parallelogram into two congruent triangles. How does thinking of each triangle as half a parallelogram show that this type of triangle will tessellate?
- Which types of triangles tessellate?

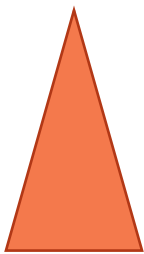

Reflecting

- Why do you think that any acute, right, or obtuse triangle can be drawn as half a parallelogram?
- When you create a tessellation with triangles, why are there always two copies of each angle at each vertex?

WORK WITH the Math

Example 1 Using transformations to tessellate a triangle

Create a tessellation with a right triangle.



Taira's Solution: Reflecting and translating

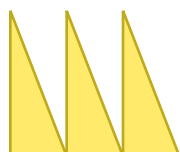

I used geometry software to translate the triangle 0 cm up and the distance of the base to the right a few times to make a row.

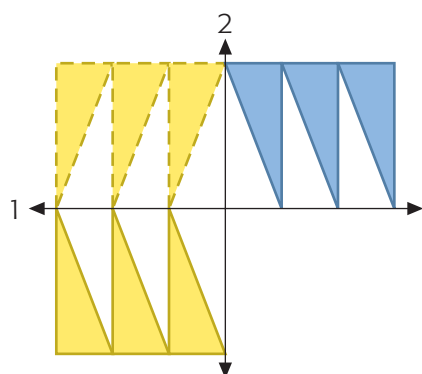

I drew a horizontal reflection line and reflected the row across it. Then I drew a vertical reflection line and reflected the top row across that.

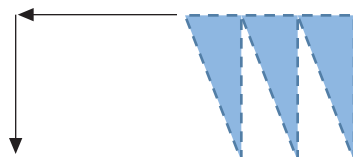

Then I translated the reflected row enough units to the left and down to fit it in the gaps of the original row.

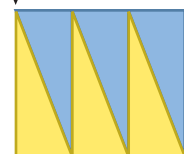

I translated the six right triangles until they tiled the plane.

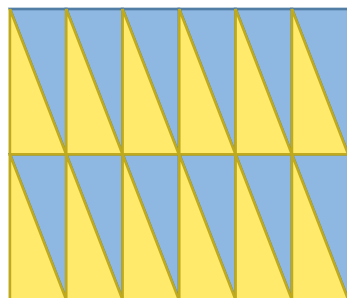

John's Solution: Rotating about a vertex and translating

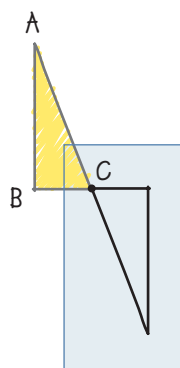

I rotated the triangle 180° clockwise (cw) about point C.

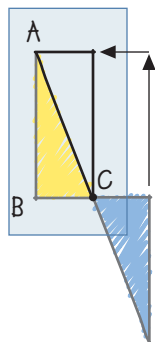

Then I slid the rotated triangle up the same distance as the height and to the left the length of the base so that the two hypotenuses matched up. The two right triangles formed a rectangle.

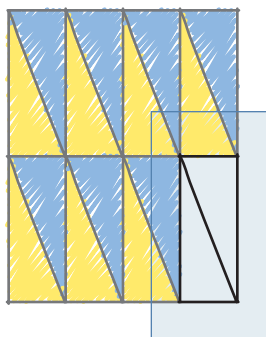

I translated the rectangle until I knew that the tessellation could be extended forever.

Angèle's Solution: Rotating about a midpoint and translating

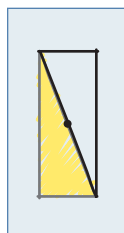

I constructed the midpoint of the hypotenuse. I rotated the triangle 180° cw about that midpoint. The two triangles formed a rectangle.

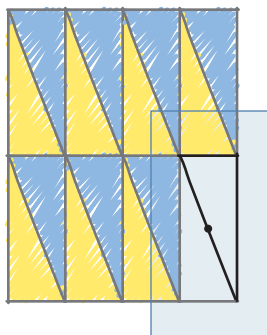

I translated the rectangle until I knew the tessellation could be extended forever.

Example 2 Using rotation to tessellate

Create a tessellation with a scalene triangle.

Ivan's Solution

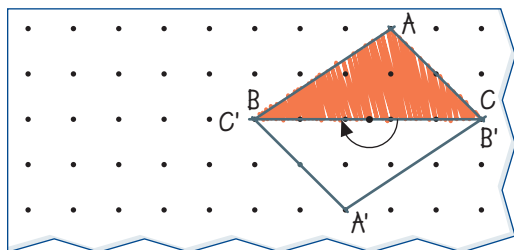
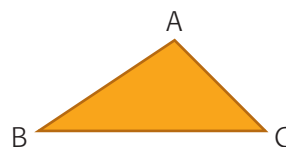

I started by rotating the triangle 180° cw about the midpoint of BC .

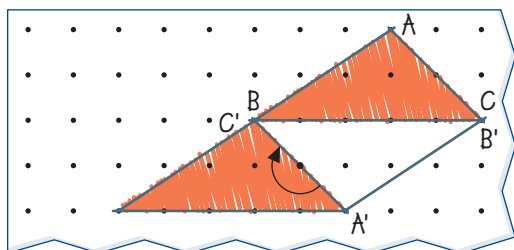

Then I rotated the new triangle 180° cw about the midpoint of $A'C'$.

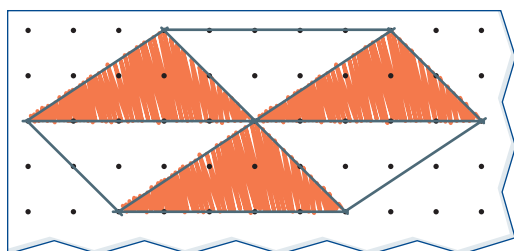

I continued to rotate about the midpoint of each side until the triangles formed a hexagon.

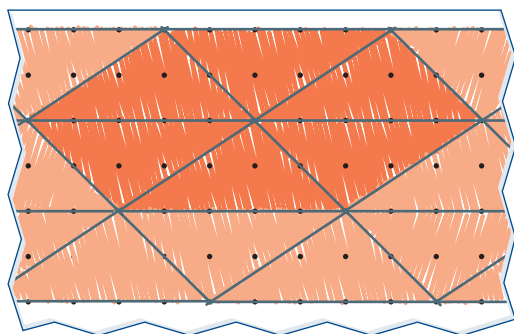

I tessellated with the hexagon until I knew it could be repeated forever.



Lam's Solution

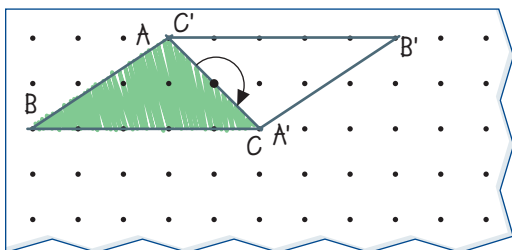

I started by rotating the triangle 180° cw about the midpoint of AC.

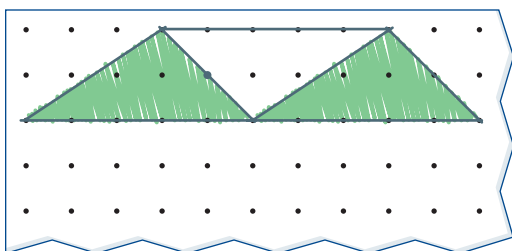

I made a row of triangles that formed a trapezoid. I knew that a trapezoid is a quadrilateral, which always tessellates.

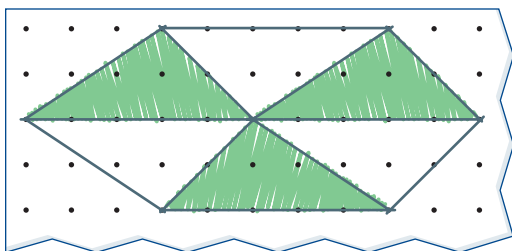

I reflected my row of triangles across a horizontal line below it.

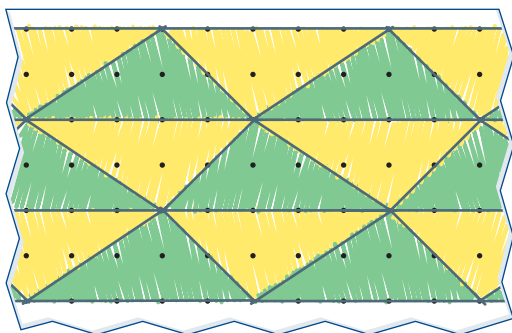

I tessellated with the trapezoid until I knew it could be extended forever.

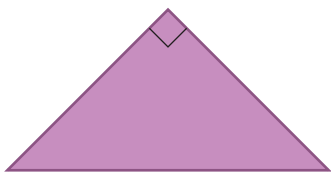

A Checking

1. Create a new shape by rotating a right isosceles triangle 180° about the midpoint of one of the sides.
 - a) What shape did you make?
 - b) Will the new shape tessellate? Explain.
2. Create a new shape by rotating a right isosceles triangle 90° either clockwise or counterclockwise about the right angle.
 - a) What shape did you make?
 - b) Will the new shape tessellate? Explain.

B Practising

3. a) Draw a scalene triangle that is different from the one below.



- b) Tessellate with your scalene triangle by rotating.
 - c) Tessellate with your scalene triangle by reflecting.
 - d) Compare the two tiling patterns that you created.
4. Create two different tessellations with an isosceles triangle. Describe how you created each.
 5. Can you always create at least two different tessellations from any triangle? Explain.



Tessera

Number of players: 2 to 4

Rules

1. Player 1 selects one card from the pile of Polygon Tile Cards.
2. Player 1 has 1 min to make a tessellation with the selected polygon. If the rest of the players agree that the design is a true tessellation, Player 1 gets one point. If the rest of the players do not agree that the design is a true tessellation, the player who correctly explains why it is not a tessellation gets one point.
3. Take turns to play until all of the polygons have been used.
4. The player with the highest score wins.

YOU WILL NEED

- 10 of each of the Polygon Tiles
- Polygon Tiles Cards I
- Polygon Tiles Cards II
- a minute timer

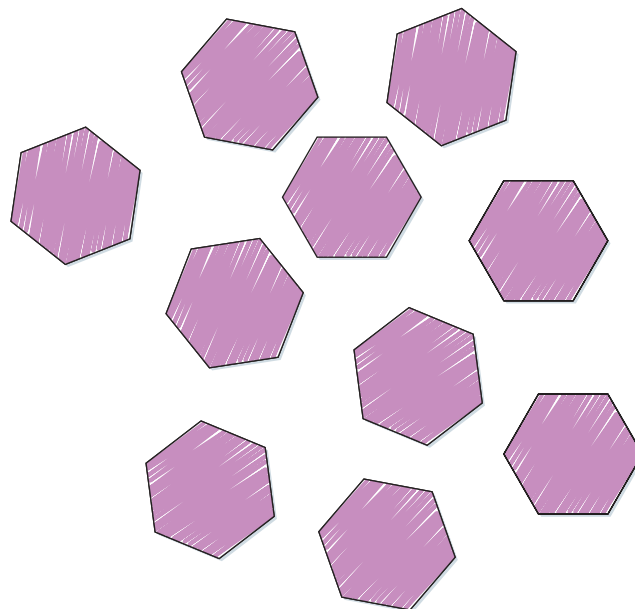
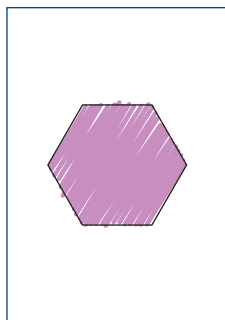

Frequently Asked Questions

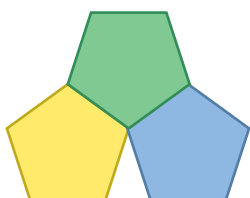

Q: How can you tell that a shape tessellates?

A: If it is not possible to arrange copies of the shape so that the angles at any vertex add up to 360° , then the shape will not tessellate.

If copies of the shape can be arranged so that the angles at each vertex add up to 360° , then you should try to tessellate it to see if it works.

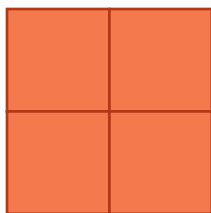

Q: Which polygons tessellate?

A: All triangles and all quadrilaterals tessellate.

Of the regular polygons, equilateral triangles, squares, and hexagons tessellate.

Q: How can you create a tessellation?

A: You can create a tessellation by translating, rotating, or reflecting the shape so that there are no gaps or overlaps.

You can then repeat the process with other copies of the combined shape.

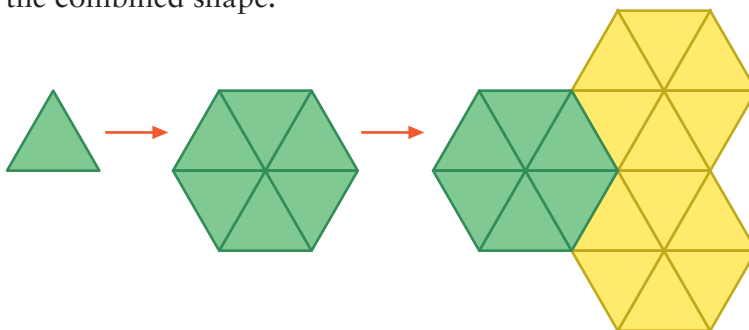

Practice

Lesson 7.2

1. A loonie is a regular 11-sided polygon. Does it tessellate? Explain.



Lesson 7.3

2. Create two different tessellations from a rhombus. Describe how you got each tessellation.



3. Karim wants to re-create this tessellation. He highlighted a section of it. What transformations of a single quadrilateral can he use to create the highlighted section?

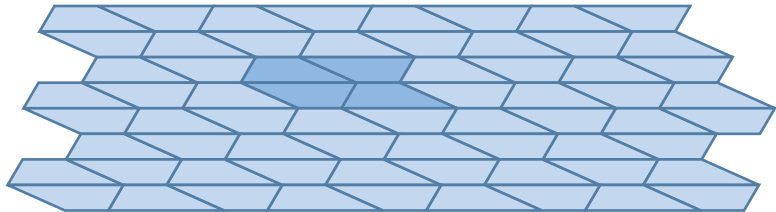

Lesson 7.4

4. Marc started to tessellate with this right isosceles triangle by rotating it 180° about the midpoint of AC . Erynn started by reflecting it across BC . Will their tessellations be the same or different? Explain.

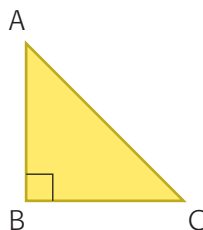

7.5

Tessellating by Combining Shapes

YOU WILL NEED

- Polygon Tiles
- Polygon Tiles Cards I
- Polygon Tiles Cards II
- grid paper

GOAL

Combine two or more regular polygons to form a tessellation.

LEARN ABOUT *the Math*

Taira is designing a tile pattern for the centre of the garden. She would like to use two regular polygons in her tessellation design.

? How can Taira choose two regular polygons that will create a tessellation if they are used together?

- Choose an equilateral triangle and a square.
What is the size of the interior angle in each shape?
- Predict which combinations of equilateral triangles and squares will tessellate. Explain your reasoning.
- Use the angle measurements in part A to predict how equilateral triangles and squares will surround each vertex in a tessellation. Explain your reasoning.
- Check your predictions in parts B and C by creating a tessellation of equilateral triangles and squares. Sketch your tessellation.
- Choose a different combination of two or more regular polygons. Predict whether this combination will tessellate. Explain your reasoning.
- Create a tessellation to check your prediction in part E.

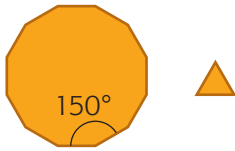

Reflecting

- G.** Each interior angle in a regular dodecagon (12 sides) is 150° . Why is it reasonable that a combination of regular dodecagons and equilateral triangles could tessellate?
- H.** Why is it helpful when the two regular polygons you are using to tessellate with have equal side lengths?

WORK WITH the Math

Example 1 | Predict tessellations based on angles

How can you tell whether combinations of regular octagons and squares will tessellate?

Ivan's Solution

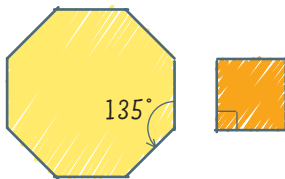

$$135^\circ + 135^\circ + 90^\circ = 360^\circ$$

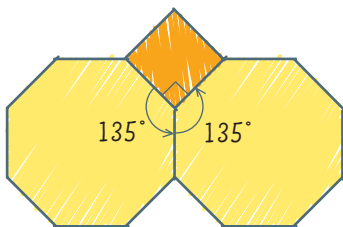

I knew from measuring that the interior angle of a regular octagon is 135° . Each interior angle of a square is 90° . I can try to tessellate the two shapes together if I can find combinations of the interior angles that add up to 360° .

I can try to tessellate by placing two octagons and one square at a vertex.

The interior angles added up to 360° . My prediction worked for the centre vertex.



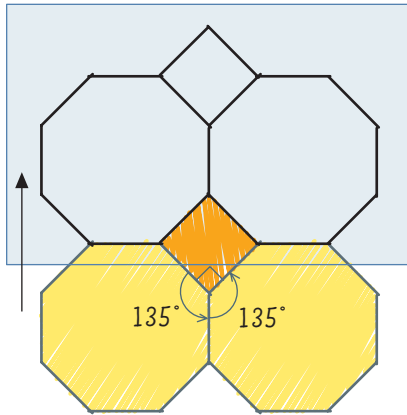

I tested my prediction. I traced the whole combination and translated it up the height of the octagon.

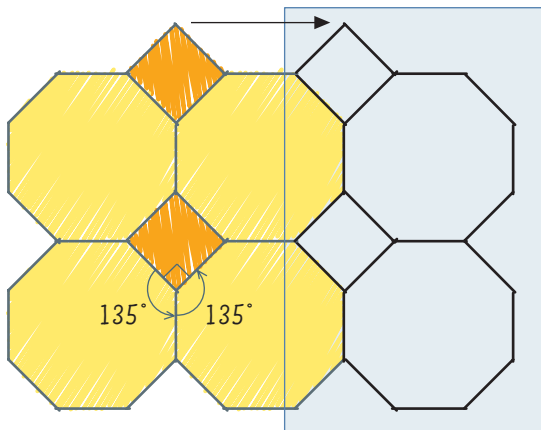

Next, I translated the square and two octagons to the right by the width of the octagon.

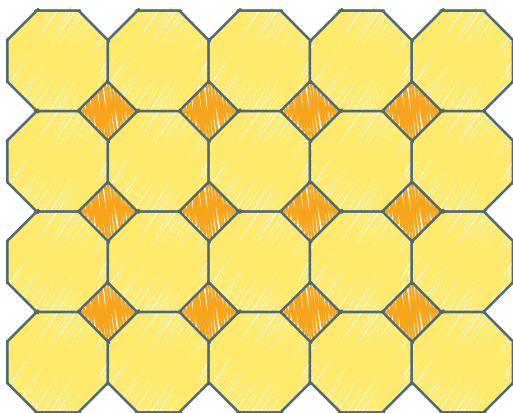

I continued the pattern until I knew it could be extended forever.

Reading Strategy

Evaluating

Choose an answer to the question. Write statements to defend your answer. Then evaluate your answer.

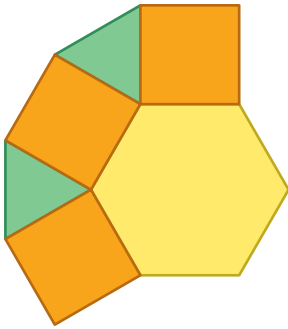

A Checking

1. Predict whether a combination of regular hexagons and squares will tessellate. Explain.

B Practising

2. Predict whether a combination of regular pentagons and equilateral triangles will tessellate. Explain.
3.
 - a) Choose two regular polygons that have not been discussed, which you think will tessellate if they are used together. Explain your choice.
 - b) Sketch your tessellation.
 - c) Describe how you got your tessellation.
4. Regular dodecagons do not tessellate. What shape could you combine with a regular dodecagon to create a tessellation? Explain.
5. Erica combined a hexagon, a square, and a triangle to start a tessellation. She is sure that it will tessellate. Do you agree? Explain.

Regular polygon (number of sides)	Approximate size of interior angles
Equilateral triangle (3)	60°
Square (4)	90°
Pentagon (5)	108°
Hexagon (6)	120°
Heptagon (7)	129°
Octagon (8)	135°
Nonagon (9)	140°
Decagon (10)	144°
Hendecagon (11)	147°
Dodecagon (12)	150°

7.6

Tessellating Designs

YOU WILL NEED

- scissors
- tracing paper
- grid paper

GOAL

Create and tessellate with an irregular polygon.

LEARN ABOUT *the Math*

John saw a copy of this M.C. Escher drawing on a poster. He wondered how the artist managed to get all of the birds to fit together so well.



He thought that Escher used a square as the basic shape for this artwork.



The black section from the top of the square can be cut out and translated to the bottom of the square.



The black section from the right of the square can also be cut out and translated to the left.

? How can you make an irregular tessellating tile?

Example 1 | Creating an irregular tile by translating

Create an irregular tessellating tile from a square.

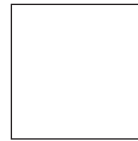

Lam's Solution

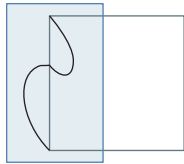

I changed the left side with a curve.

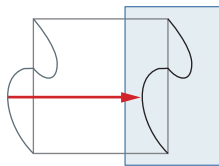

I translated the curve to the right side.

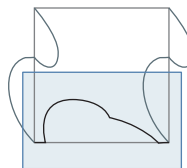

I changed the bottom of the square with another curve.

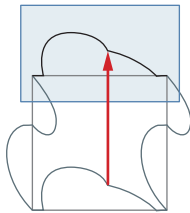

Then I translated the curve up to the top side of the square.



I thought the new tile looked like a knight on a horse. I drew in the picture and cut out the tile.



Then I translated the tile over and over to create a tessellation.

Create a tessellating shape from a regular hexagon.

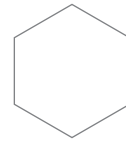

Taira's Solution

I traced a design over half of one side.

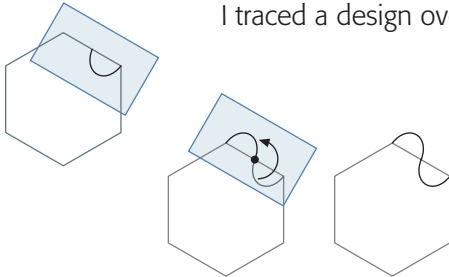

I rotated the design 180° about the midpoint of the side that I changed.

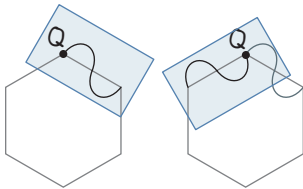

I rotated 120° cw about Q to move the design to the next side.

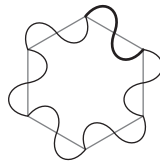

I continued to rotate and trace the design until all of the sides were changed. I thought my irregular tile would tessellate because it was created from a regular hexagon, which I know tessellates.

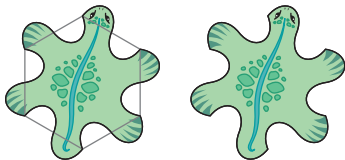

I thought that the new shape looked like a lizard, so I drew some lizard details on it. I cut out the lizard.

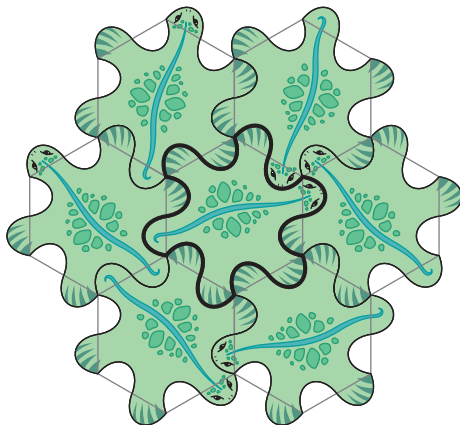

I tried to tessellate with the new tile. I was right. The tiles fit together. I continued to translate the lizard tile until I knew the tessellation could be extended forever.

Reflecting

- A. Do you think that using the strategies in Examples 1 and 2 would make a regular pentagon tile tessellate? Explain.
- B. In Example 1, the part that was cut out of one side was added to the opposite side. Why was this important to make the tessellation work?
- C. In Example 2, the rotation was done using half of each side. Why was this important to make the tessellation work?

WORK WITH the Math

Example 3 | Creating an irregular tessellating tile

Create an irregular tessellating tile from a parallelogram.

Solution



Parallelograms always tessellate.



Change one of the sides.

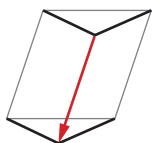

Translate the changed side to the opposite side of the shape.

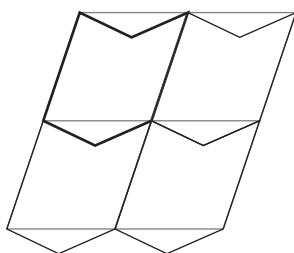

Tessellate the new shape by transforming it over and over.

A Checking

- a)** Create a new tile from a square by doing the following:
 - Change the left side and translate it to the right side.
 - Use a different change for the top and translate it to the bottom side.
 - Cut out the tile.
- b)** Will the new tile tessellate? Explain.

B Practising

- a)** Create an irregular tessellating tile from a rectangle. Sketch it.
b) Describe how you created it.
c) How do you know it will tessellate?
- Chris started to change a triangle tile by adding a bump to half of one side.
 - a)** Show how you could finish changing the tile so that it will tessellate.
 - b)** How do you know your new tile will tessellate?
 - c)** Decorate the shape to make a design.
- This fish tessellation pattern was created by M.C. Escher.
 - a)** What basic shape do you think Escher started with?
 - b)** What transformations do you think Escher did with his basic shape? Explain.
 - c)** Look at the side of the basic shape that has the fish with the double tail fin. How did Escher change this side of the basic shape?
- Draw a square. Change each side by drawing a curve from one vertex to the adjacent vertex. Is it likely that this shape will tessellate? Explain.

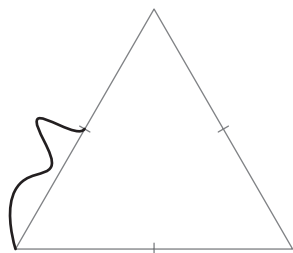

7.7

Exploring Tessellations in the Environment

GOAL

Investigate tessellations in the environment.

EXPLORE the Math

Ivan and Holly saw these patterns around their school and decided they are tessellations.

What other tessellations do you see around your school?

? How did people create the tessellations that you have seen?



7.8

Communicate about Tessellations

GOAL

Describe the transformations in a tessellation.

LEARN ABOUT *the Math*

John created this tessellation design.

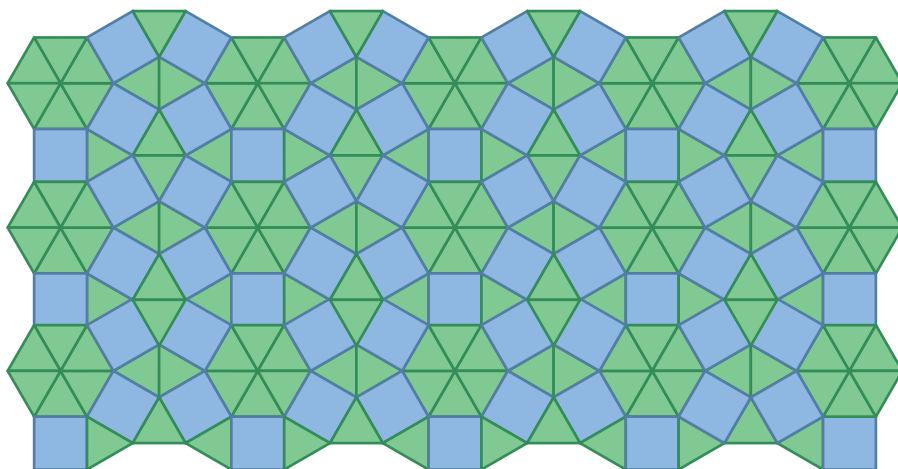

Renée wants to make the same design on a computer. John tries to describe the tessellation to Renée.

? How can John improve his description?

John's Description

Renée's Questions

I placed three triangles and two squares together in a pattern of triangle, triangle, square, triangle, square.



I put more squares against the triangles and more triangles against the squares.

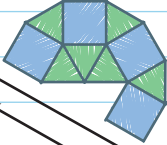

I continued until I ran out of tiles.

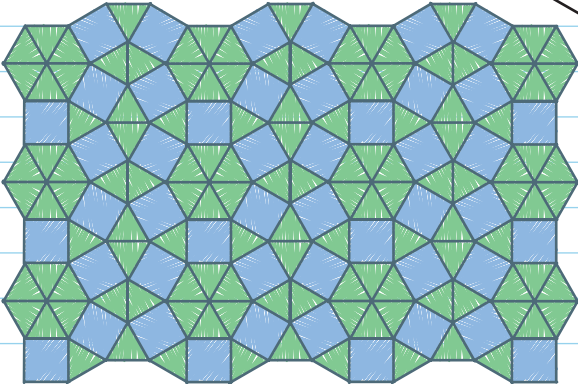

Communication Checklist

- ✓ Did you clearly explain all the steps in your reasoning?
- ✓ Did you use pictures or diagrams to show your steps?
- ✓ Did you use words and pictures that were mathematically clear and correct?
- ✓ Did you justify your conclusions?

- A. Use Renée's questions and the Communication Checklist to improve John's description.
- B. Which parts of the Communication Checklist did Renée deal with in her questions?

Reflecting

- C. Which parts of John's tessellation is hardest to describe using only words? Why?
- D. How do the sketches make John's description easier to understand?

WORK WITH the Math

Example 1 | Describing the steps for a tessellation

Explain how you would create this tessellation.

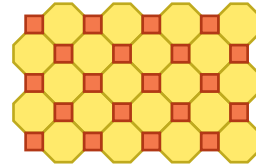

Solution



Start with just octagons. The vertex angles do not add up to 360° .



The gap between the octagons is exactly 90° . Add a square to the vertex.

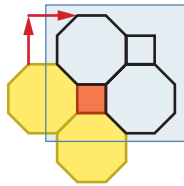

Translate the two octagons and the square up and to the right so the bottom left sides of the new position of the octagons sit against the top right sides of the old ones.

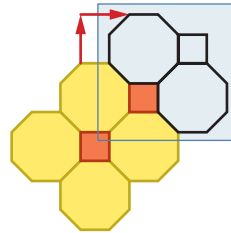

Translate the octagons up to the right again. Each gap is filled by a square with each side length being one unit.

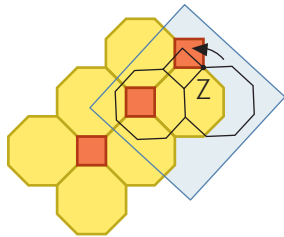

Rotate the last two octagons and square 90° cw around vertex Z.

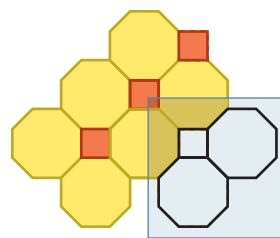

Then translate the rotated shapes down.

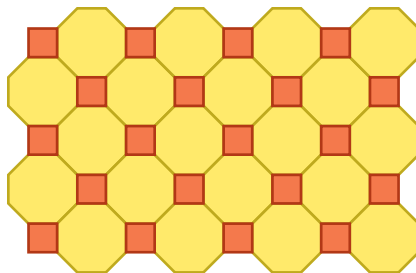

Continue until you think the shapes can be repeated forever. There are no gaps, and the angle measurements at each vertex add up to 360° .

A Checking

1. Describe how to tessellate with a regular hexagon.

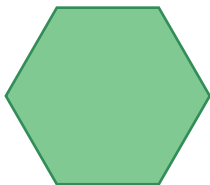

B Practising

2. Use the Communication Checklist to help you explain why regular pentagons do not tessellate.

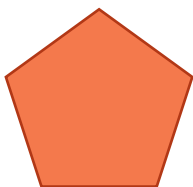

3. Find a picture of a tessellation. Describe how the artist might have created the tessellation.
4.
 - a) Determine two ways to tessellate with a kite.
 - b) Compare the two tessellations. Use the Communication Checklist to improve your comparison.



Alphabet Tessellations

YOU WILL NEED

- Alphabet Letters



Shapes that tessellate can be created to look like letters of the alphabet.

For example, here is a tessellation for the letter "a."

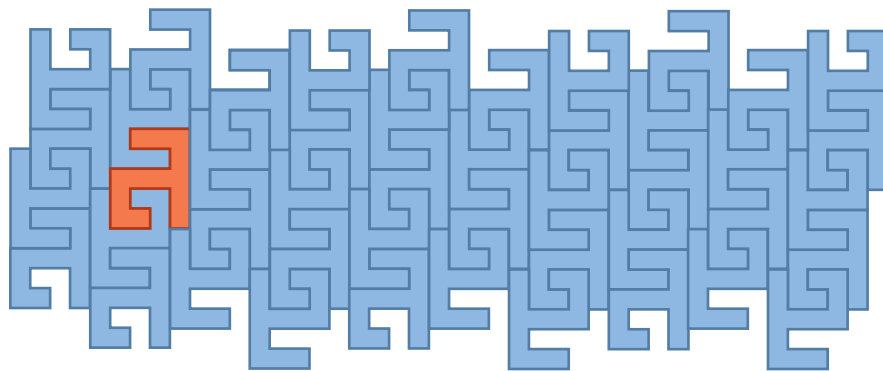

1. Choose two other letters to show that they tile.
2. Make your own version of a stylized letter that tessellates.

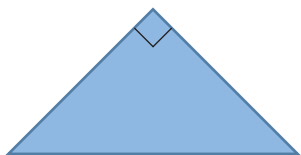

1. Determine whether each tile can tessellate.

Explain your answers.

a)

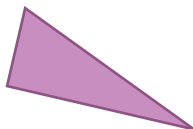

b)

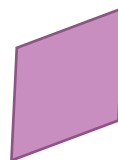

2. a) Create a tessellation with a regular dodecagon and two other regular polygons.
 b) Describe your tessellation using transformations.
3. Bill started to tessellate with a right isosceles triangle by reflecting across the hypotenuse. Derek started by rotating about the midpoint of the hypotenuse. Compare the two patterns.
4. a) Combine squares and equilateral triangles to meet at a single vertex.
 b) Try to tessellate that combination of shapes using transformations.
 c) Does it tessellate? Explain.
5. a) Use rotations or translations to modify this trapezoid.
 b) Use the new shape to create a tessellation.

What Do You Think Now?

Revisit What Do You Think? on page 287. How have your answers and explanations changed?

Frequently Asked Questions

Q: How can you choose regular polygons to combine to make a new shape that tessellates?

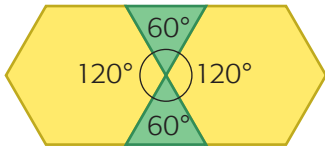

A: Examine the interior angles of the regular polygons. Choose combinations of angles that add up to 360° . Make sure the side lengths of all of the polygons are the same. Try to tessellate the combination.

For example, the interior angles of two hexagons and two triangles add up to 360° .

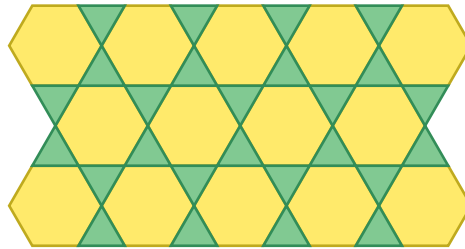

Q: How can you change a tile so that it will tessellate?

A: Start with a shape that you know will tessellate. Change the opposite sides the same way, using appropriate transformations.

Translation

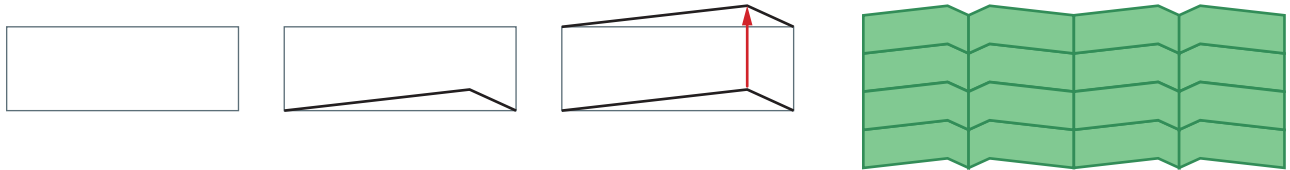

Rotation

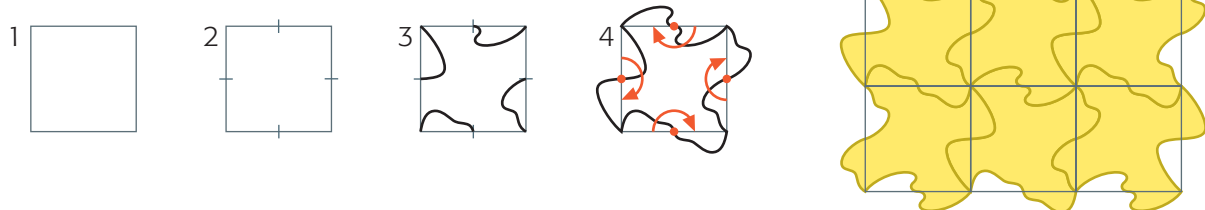

Practice

Lesson 7.2

- The hardware store does not sell nonagon-shaped (9-sided) tiles. Use angle measurements to explain why.

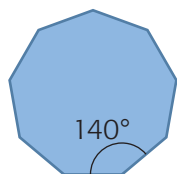

Lesson 7.3

- Create a tessellation with this quadrilateral.
 - Can the tessellation be done another way? Explain.



- Sabrina says that this quadrilateral does not tessellate even though the angle sum at the centre vertex is 360° . Do you agree? Explain your thinking.

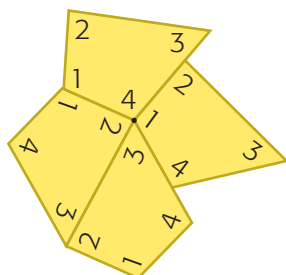

Lesson 7.4

- Yifan tessellated with a triangle this way.

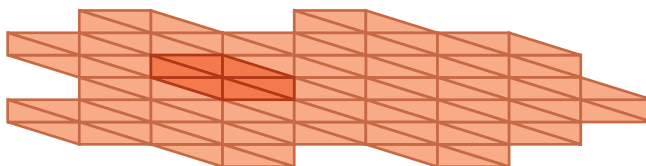

Patrick tessellated with the same triangle this way.

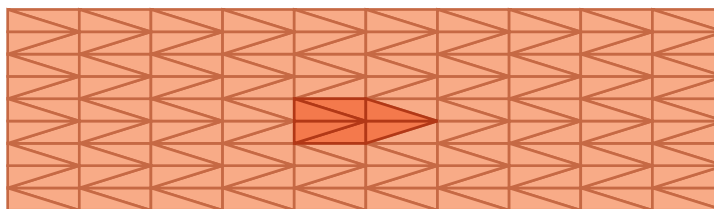

How did Yifan and Patrick transform the triangle differently to create their tessellations?

Lesson 7.5

- A regular dodecagon has interior angles of 150° . Which two polygons could you combine it with to create a tessellation? Explain your reasoning.

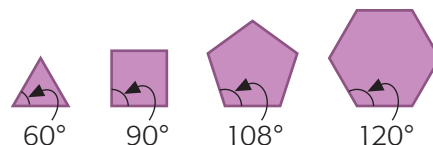
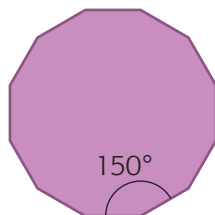

Lesson 7.6

- Change a kite tile to make a tessellating design. Explain what you did to change the tile.

Task | Checklist

- ✓ Did you choose a polygon that could tessellate?
- ✓ Did you describe the modification and the tessellation using transformation words?
- ✓ Did you use diagrams in your description?
- ✓ Did you show all of your steps?

Wall Design

You have been asked to create a tessellation design for the wall of your school's main entrance. The school wants to use a modified tile that is decorated with a symbol of the school.

? How can you tessellate with a modified tile for the school wall?

- A. Choose a polygon to start with.
- B. Modify the polygon any way you wish.
- C. Decorate your modified polygon with a symbol of your school.
- D. Tessellate with your modified polygon.
- E. Write a detailed description that someone else could follow to recreate your tessellation design.

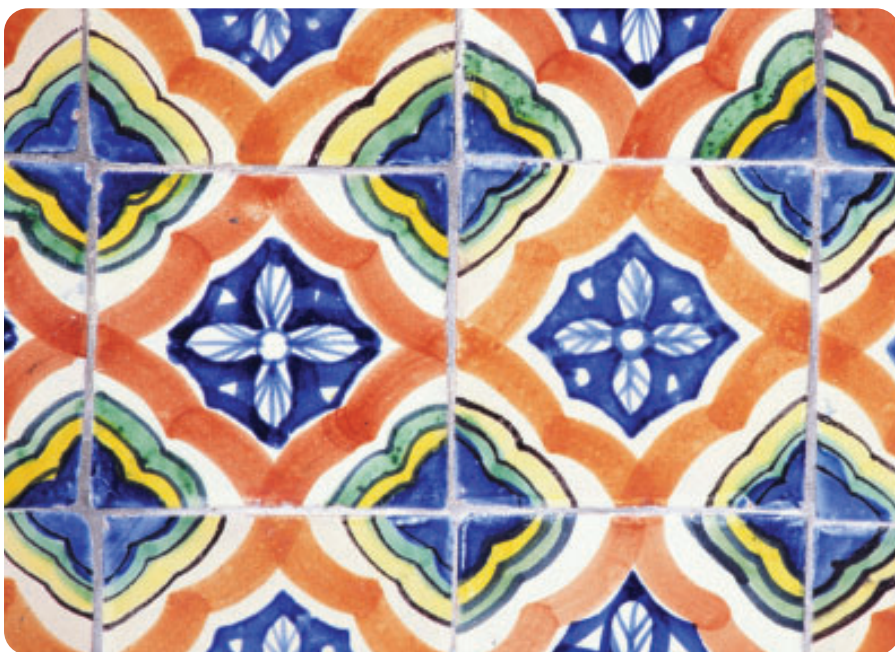

1. Which block would you have to attach to a yellow hexagon pattern block to make the total area 150% of the original area?

A.



C.



B.



D.



2. The number of elk at a park increased by 5% in 2006 and by 10% in 2007. What is the two-year percent increase in the elk population?

- A. 15.5% B. 15% C. 115% D. 115.5%

3. Daria earns a commission of 5.3% of the value of her sales. What would her commission be on sales worth \$150 000.00?

- A. \$79 500.00 C. \$795.00
B. \$7 950.00 D. \$79.50

4. Which of the following does NOT represent the same percent as the others?

- A. 0.0625 B. 6.25% C. $\frac{1}{16}$ D. $\frac{25}{4}$

5. Which net(s) will fold to make the object to the left?

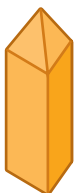

A.



C.

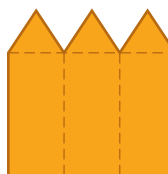

B.

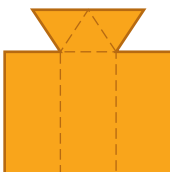

D. all of them

6. Which list correctly orders the following shapes from least surface area to greatest surface area?

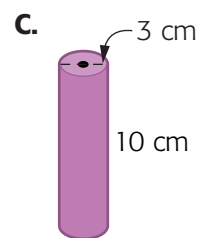
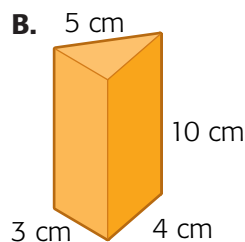
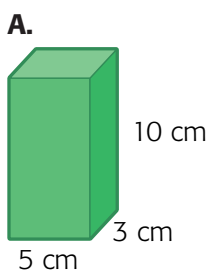

- A.** A, B, C **B.** A, C, B **C.** C, B, A **D.** B, A, C

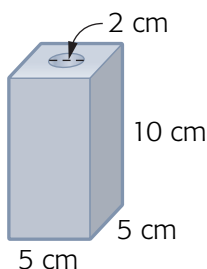

7. A metal prism has a cylindrical hole drilled through it as shown at the left. What percent of the original volume of the prism remains?

- A.** less than 60% **C.** between 70% and 80%
B. between 60% and 70% **D.** between 80% and 90%

8. Which expression is most correctly represented by the following picture?

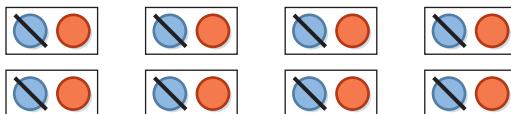

- A.** $2(4)$ **B.** $2(-4)$ **C.** $-2(4)$ **D.** $-2(-4)$

9. Inigo calculated the value of $\frac{-36 + [1 - (-5)]}{2(-3)}$ to be 7.

Which operation did Inigo most likely do incorrectly?

- A.** addition **C.** multiplication
B. subtraction **D.** division

10. Which of the following regular polygon tiles will NOT tessellate?

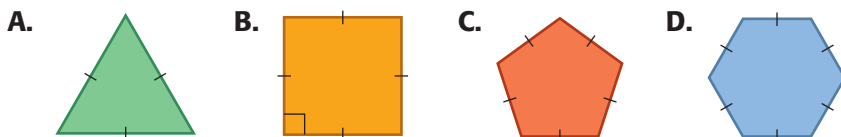

11. What percent of the regular polygons with 10 or fewer sides can be made to tessellate?

- A.** 37.5 % **B.** 33.3 % **C.** 30 % **D.** 20 %